

TECO

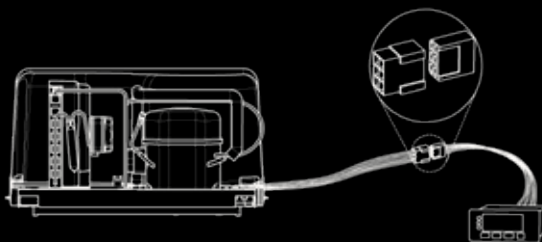

### Monoblocchi frigoriferi per Armadi

#### Vantaggi Economici

- riduzione costi di installazione.
- riduzione costi di gestione.
- riduzione costi post-vendita.

#### Vantaggi Costruttivi

- rapida installazione.
- cablaggi elettrici immediati.
- evaporatore integrato nell'unità, vano frigorifero libero da ingombri
- evaporazione autonoma dell'acqua di condensa.
- dimensioni unificate delle unità, evitano la diversificazione di produzione di armadi e banchi.

#### Tecnologia Innovativa

- struttura realizzata con materiali d'avanguardia per uso alimentare.
- rendimenti frigoriferi elevati.
- gas refrigeranti ecologici.
- ventilazione forzata.
- unità tropicalizzate (+38/+43°C).



### Cooling Plug-in units for cabinets

#### Economic Advantages

- reduced installation costs.
- reduced running costs.
- reduced after-sales costs.

#### Construction Advantages

- fast installation.
- immediate electrical wiring.
- evaporator built into the unit so that no space in the refrigerating compartment is taken up.
- autonomous evaporation of condensation.
- units are of unified sizes, which avoids diversifying production of cabinets and refrigerator counters.

#### Innovative Technology

- structure made using food-safe cutting-edge materials .
- high refrigerating performance.
- ecological refrigerating gases.
- forced ventilation.
- units suitable for tropical temperatures (+38/+43°C).



## Monoblocs frigorifiques pour Armoires

### Avantages Economiques

- réduction des coûts d'installation.
- réduction des coûts de gestion.
- réduction des coûts après-vente.

### Avantages Structuraux

- installation rapide.
- câblages électriques immédiats.
- évaporateur intégré à l'unité, compartiment frigorifique sans encombrements.
- évaporation autonome de l'eau de condensation.
- dimensions unifiées des unités, évitant la diversification de production d'armoires et de comptoirs.

### Technologie Innovante

- structure réalisée avec des matériaux d'avant-garde à usage alimentaire.
- hauts rendements frigorifiques.
- gaz réfrigérants écologiques.
- ventilation forcée.
- unités tropicalisées (+38/+43° C).



## Kühlblöcke für Kühlschränke

### Wirtschaftliche Vorteile

- Reduzierte Installationskosten.
- Reduzierte Betriebskosten.
- Reduzierte After-Sales-Kosten.

### Konstruktionsvorteile

- Schnelle Installation.
- Einfache elektrische Anschlüsse.
- Verdampfer in die Kühleinheit integriert, komplett freier Kühlbereich.
- Automatische Kondenswasserverdunstung.
- Dank der standardisierten Maße der Kühleinheiten geringere Diversifikation bei der Produktion von Kühlschränken und -theben.

### Innovative Technologie

- Struktur aus fortschrittlichen, lebensmittelverträglichen Materialien.
- Hohe Kühlleistung.
- Umweltfreundliche Kühlgase.
- Zwangslüftung.
- Tropenfeste Einheiten (+38/+43°C).



## Monobloques frigoríficos para Armarios

### Ventajas Económicas

- reducción de los costos de instalación.
- reducción de los costos de gestión.
- reducción de los costos post-venta.

### Ventajas Constructivas

- rápida instalación.
- cableados eléctricos inmediatos.
- evaporador integrado en la unidad, vano frigorífico libre de ocupaciones.
- evaporación autónoma del agua de condensación.
- dimensiones unificadas de la unidad para evitar la diversificación de producción de armarios y bancos.

### Tecnología Innovadora

- estructura realizada con materiales de vanguardia para uso alimentario.
- rendimientos frigoríficos elevados.
- gases refrigerantes ecológicos.
- ventilación forzada.
- unidades tropicalizadas (+38/+43°C).

### Installazione - Installation

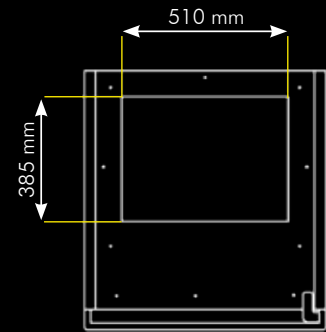
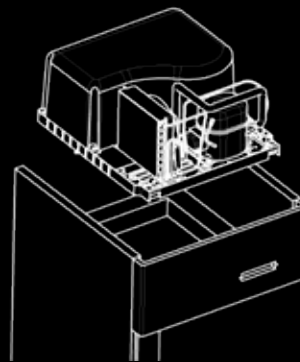

Hole Dimension

### Dimensioni - Dimensions



### Working Condition ST52 PL / PLR

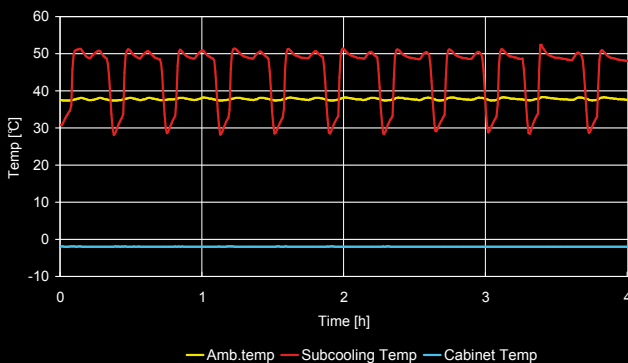

	Alimentazione Supply	Potenza Frigorifera Comp. Comp. Cooling Capacity	Potenza Elettrica Power Consumption	Gas Ecologico Ecological Gas	Volume Refrigerato Refrigerated Volume	Temperatura d'impiego Operating Temperature	Peso Weight
<b>ST52 PL</b>	230V - 50Hz	340 W*	330 W*	R134a	700 lt	+2/+8°C	18 Kg
<b>ST52 PLR</b>	230V - 50Hz	340 W*	330 W*	R134a	700 lt	-2/+8°C	18 Kg

Tutti i dati sono indicativi e possono essere variati senza preavviso da TECO. All data are approximate and may be changed without notice by TECO.

\* Ashrae: amb. - room +35°C / evap. -8°C / cond. +55°C.

